

FILO+

Design Enrico Cesana

ARTESI

FILO+ System

Una collezione, infinite possibilità.

La nuova collezione Filo+ si caratterizza per un design pulito e rigoroso.

Un progetto che fa della personalizzazione la sua massima espressione, quattro possibili tipologie di apertura offrono molteplici possibilità compositive. Sono disponibili diverse varianti di finiture per i fianchi che permettono di valorizzare per contrasto o in abbinamento le superfici e dare ancora maggior risalto e valore al mobile. La nuova finitura Logic, caratterizzata da sottili linee parallele orizzontali incise nel frontale, conferisce una nuova tridimensionalità.

One collection, infinite possibilities. The new Filo + collection is characterized by a clean and rigorous design.

A project that best expresses itself through personalisation: four possible opening typologies offer several compositional possibilities. Sides are available in various finishes, thus allowing to enhance the surfaces by contrast or matching them, giving in this way even more prominence and value to the piece of furniture. The new Logic finish, characterized by thin horizontal parallel lines engraved on the front, lends a new three-dimensional look.

Eine Kollektion, unendliche Möglichkeiten. Die neue Kollektion Filo + zeichnet sich durch ein klares und strenges Design aus. Ein Projekt, das sich am besten durch Personalisierung ausdrückt: vier mögliche Eröffnungstypologien bieten verschiedene Kompositionsmöglichkeiten. Die Seiten sind in verschiedenen Ausführungen erhältlich, so dass die Oberflächen durch Farbkontrast oder Farbanpassung aufgewertet werden können und das Möbel auf diese Weise noch deutlicher und exklusiver wird. Die neue Tür Logic, die durch dünne horizontale und parallele Linien auf der Front gekennzeichnet ist, verleiht einen neuen dreidimensionalen Look.

Une collection, des possibilités infinies. La nouvelle collection Filo + se caractérise par un design épuré et rigoureux.

Un projet qui s'exprime au mieux par la personnalisation: quatre typologies d'ouverture possibles offrent plusieurs possibilités de composition. Les côtés sont disponibles en différentes finitions, permettant ainsi de rehausser les surfaces par contraste ou de les assortir, donnant ainsi encore plus d'importance et de valeur aux meubles. La nouvelle façade Logic, caractérisée par de fines lignes parallèles horizontales gravées sur la surface, donne un nouveau look tridimensionnel.

PG.04

1/ VERTICAL



PG.30

2/ HORIZON



Definisci il tuo stile.

Progettisti e clienti hanno a disposizione una combinazione infinita di soluzioni per la personalizzazione dell'ambiente bagno.

Choose your style.
Designers and customers have infinite combinations of solutions to personalize the bathroom.

Wählen Sie Ihren Stil.
Designer und Kunden haben unendliche Lösungskombinationen, um das Badezimmer individuell zu gestalten.

Choisissez votre style.
Les designer et les clients ont une combinaison infinie de solutions pour personnaliser la salle de bain.

PG.56

4/ PLAIN



PG.84

5/ PUSH & HANDLES



Filo+

—— Vertical

La maniglia diventa verticale e si posiziona lateralmente creando un segno grafico unico e riconoscibile. Un segno essenziale e rigoroso che crea nuove estetiche quotidiane. Tono su tono oppure a contrasto la maniglia ridefinisce il look del mobile.

The handle becomes vertical and side positioned, creating a unique and recognizable graphic sign. An essential and rigorous line that creates new daily aesthetics. Tone on tone or in contrast: the handle gives a new look to the furniture.

Der Griff wird vertikal und seitlich positioniert, wodurch ein eindeutiges und erkennbares grafisches Zeichen entsteht. Eine wesentliche und strenge Form, die eine neue tägliche Ästhetik schafft. Ton in Ton oder im Kontrast: Der Griff verleiht den Möbeln einen neuen Look.

La poignée devient verticale et est positionnée latéralement créant un signe graphique unique et reconnaissable. Un signe essentiel et rigoureux qui crée une nouvelle esthétique au quotidien. Ton sur ton ou en contraste, la poignée redéfinit le look du meuble.









Nuovo lavabo Rail con fascia esterna laccata

Rail: the vanity top with external lacquered band
Rail: der Waschtisch mit außen lackiertem Band
Plan vasque Rail avec bande extérieure laquée







1 / **Filo+ Vertical**

Roccia Opaco / Top Rail Bianco e Roccia Opaco
Roccia matt / Vanity top Rail - White and Roccia matt
Roccia matt / Waschtisch Rail - Weiß und Roccia matt
Roccia mat / Plan vasque Rail - Blanc et Roccia mat

Comp. FP 01 L.170,4 X P.45,9 cm





2 / **Filo+ Vertical** ---

Creta Opaco / Top Campus Creta
Creta matt / Vanity top Campus - Creta
Creta matt / Waschtisch Campus - Creta
Creta mat / Plan vasque Campus - Creta

Comp. FP 02 L.120,4 X P.50,4 cm



Nuovo lavabo Campus con finitura in Ecomalta

Campus: the vanity top in Ecomalta (Ecological mortar) finish
Campus: der Waschtisch in Ecomalta Ausführung (ökologischer Mörtel)
Plan vasque Campus avec finition en Ecomalta (mortier de ciment écologique)











3 / Filo+ Vertical

Grigio Londra Opaco / Top Reef Grigio

Grigio Londra matt / Top Reef with integrated basin - Grigio

Grigio Londra matt / Abdeckplatte Reef mit integriertem Becken - Grigio

Grigio Londra mat / Plan Reef avec vasque intégrée - Grigio

Comp. FP 03 L.255,4 X P.45,9 cm







4 / **Filo+ Vertical** ---

Cenere Opaco / Nebbia Opaco / Consolle Flip Cenere
Cenere matt / Nebbia matt / Vanity top Flip - Cenere
Cenere matt / Nebbia matt / Waschtisch Flip - Cenere
Cenere mat / Nebbia mat / Plan vasque Flip - Cenere

Comp. FP 04 L.190,4 X P.51,5 cm







5/

———— Filo+ Vertical

Piombo Opaco / Top Stone Piombo

Piombo matt / Top Stone with integrated basin - Piombo

Piombo matt / Abdeckplatte Stone mit integriertem Becken - Piombo

Piombo mat / Plan Stone avec vasque intégrée - Piombo

Comp. FP 05 L.70,4 X P.50,4 cm







Filo+

—— Horizon

La gola in alluminio è il segno distintivo, un tratto semplice, deciso e geometrico. La maniglia si integra nell'anta e permette di definire abbinamenti cromatici in nuance con il frontale oppure a contrasto in grado di rispondere ad ogni esigenza estetica.

The aluminium groove is here the distinguishing feature; a simple, resolute and geometric line. The handle is integrated into the door surface. It allows you to make a chromatic combination with the front, by choosing a matching or a contrasting colour, thus meeting any aesthetic need.

Die Griffmulde aus Aluminium ist hier das charakteristische Merkmal: eine einfache, entschlossene und geometrische Linie. Der Griff ist in die Türfront integriert. Sie können eine chromatische Kombination mit der Front vorsehen, indem Sie eine passende oder kontrastierende Farbe auswählen: man kann allen ästhetischen Erfordernissen genügen.

La gorge en aluminium est la marque de fabrique, une ligne simple, résolue et géométrique. La poignée est intégrée dans la porte et vous permet de définir des combinaisons chromatiques en nuance avec la façade ou en contraste, répondant ainsi à tout besoin esthétique.









6 / Filo+ Horizon

Quarzo Opaco / Roccia Opaco / Top Quarzo Opaco / Lavabo Blob
Quarzo matt / Roccia matt / Top Quarzo matt / Basin Blob
Quarzo matt / Roccia matt / Abdeckplatte Quarzo matt / Becken Blob
Quarzo mat / Roccia mat / Plan Quarzo mat / Lavabo Blob

Comp. FP 06 L.180,4 X P.45,9 cm





Nuova anta finitura Logic

Sottili linee parallele orizzontali incidono i frontali dell'anta, conferendo tridimensionalità alla superficie e vestendo il mobile con un effetto che genera un'innovativa leggerezza. Distanziate tra loro di 25 mm, le fessature scandiscono lo sviluppo orizzontale del contenitore, arricchendo di un nuovo grafismo l'intero progetto.

New door Logic. Thin parallel horizontal lines engrave the door front, lending to the surface a three-dimensional look and giving the furniture an effect of innovative lightness. Engravings are 25 mm apart and characterise the horizontal development of the cabinets, enhancing the entire project with a new graphic style.

Neue Tür Logic. Dünne parallele horizontale Linien gravieren die Türfront und verleihen der Oberfläche ein dreidimensionales Aussehen, das den Möbeln einen Effekt innovativer Leichtigkeit verleiht. Gravuren haben einen Abstand von 25 mm und kennzeichnen die horizontale Entwicklung des Unterschranks, wodurch das gesamte Projekt mit einem neuen Grafikstil aufgewertet wird.

Nouvelle porte Logic. De fines lignes horizontales parallèles affectent la façade de la porte, donnant à la surface une dimension tridimensionnelle et aux meubles un effet qui génère une légèreté innovante. Les gravures sont espacées de 25 mm et caractérisent le développement horizontal des meubles, améliorant l'ensemble du projet avec un nouveau style graphique.











7 / **Filo+ Horizon**

Rovere Fumè / Creta Opaco / Top Rovere Fumè / Lavabi Coppa Bianco Opaco
Oak Fumé / Creta matt /Top Oak Fumé / Basins Coppa -White matt
Eiche Fumé /Creta matt / Abdeckplatte Eiche Fumé / Becken Coppa -Weiß matt
Chêne Fumé /Creta mat / Plan Chêne Fumé / Lavabos Coppa - Blanc mat

Comp. FP 07 L.290,4 X P.50,4 cm



8 / **Filo+ Horizon** ---

Bianco Opaco / Top Tender Bianco Opaco
White matt / Vanity top Tender - White matt
Weiß matt / Waschtisch Tender - Weiß matt
Blanc mat / Plan vasque Tender - Blanc mat

Comp. FP 08 L.180,4 X P.45,9 cm





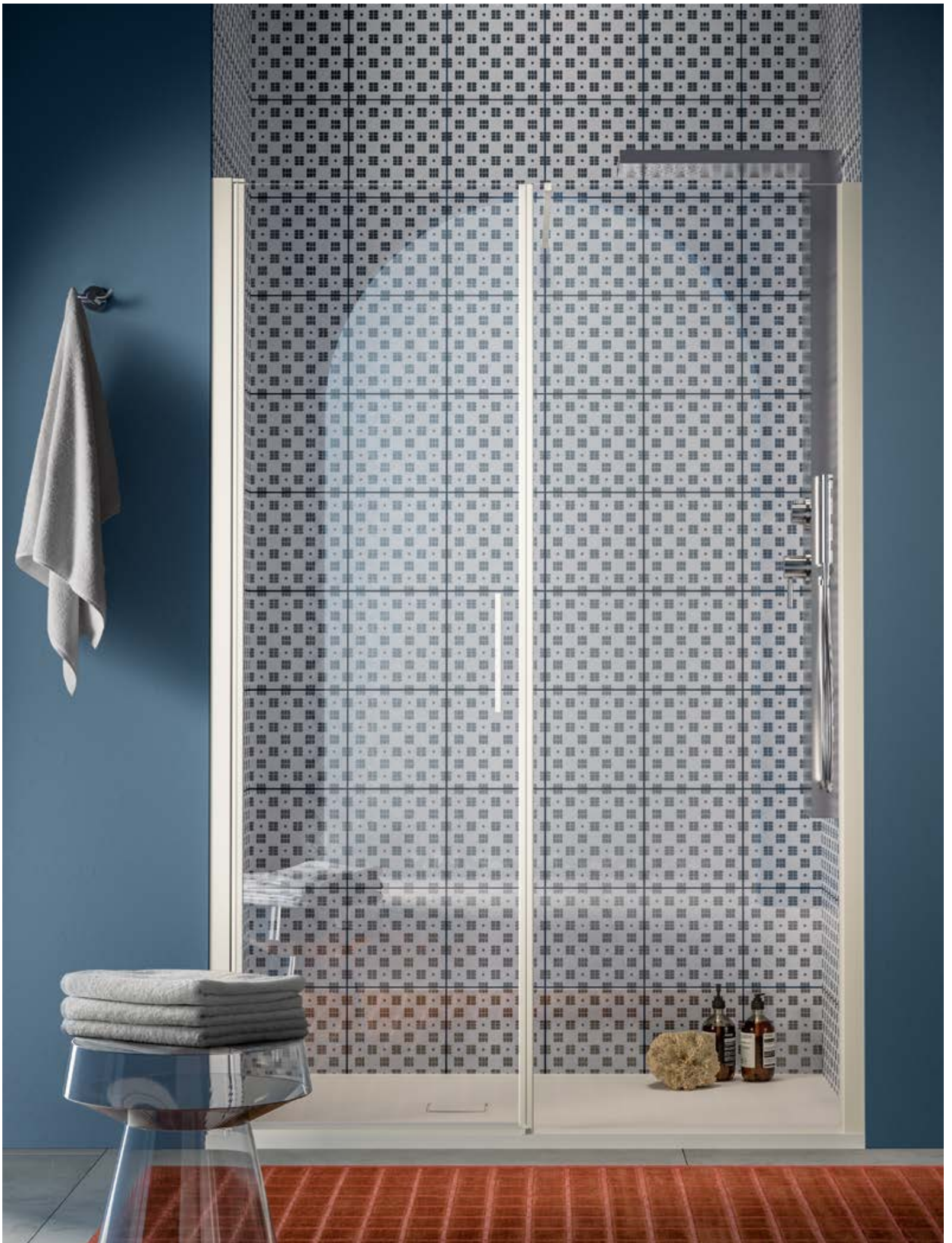







9 / **Filo+ Horizon**

Piombo Opaco / Consolle Flip Piombo
Piombo matt / Vanity top Flip - Piombo
Piombo matt / Waschtisch Flip - Piombo
Piombo mat / Plan vasque Flip - Piombo

Comp. FP 09 L.121 X P.51,5 cm















10 / **Filo+ Horizon**

Paulownia Grigio / Top Stone Matt Piombo / Lavabi Ombra Bianco Opaco

Paulownia Grigio / Top Stone Matt - Piombo / Basins Ombra - White matt

Paulownia Grigio / Abdeckplatte Stone Matt - Piombo / Becken Ombra - Weiß matt

Paulownia Grigio / Plan Stone Matt - Piombo / Lavabos Ombra - Blanc mat

Comp. FP 10 L.350 X P.45,9 cm

Filo+

— Plain

Un sottile profilo in alluminio crea un segno orizzontale, continuo, grafico e lineare. Finiture nickel o colorate permettono di liberare la progettualità e personalizzare gli abbinamenti. Con utilizzo al profilo fianco terminale assume l'estetica e la preziosità di un'anta con telaio.

A thin aluminium profile creates a horizontal, continuous, graphic and linear sign. It is available in nickel or coloured finishes, so that you can plan totally free your bathroom and personalize the combinations. If you match it with an optional metal profile for the side, the aesthetics and preciousness will be those ones of a door with frame.

Ein dünnes Aluminiumprofil erzeugt ein horizontales, ununterbrochenes, grafisches und lineares Zeichen. Das Profil ist in Nickel oder farbigen Ausführungen erhältlich, so dass Sie Ihr Badezimmer frei planen können und die verschiedene Kompositionen personalisieren. Wenn Sie diesen Griff mit einem optionalen Metallprofil für die Seite kombinieren, werden Ästhetik und Kostbarkeit die einer Tür mit Rahmen sein.

Un profil mince en aluminium crée une ligne horizontale, continue, graphique et linéaire. Les finitions nickel ou colorées permettent de projeter en liberté et de personnaliser les combinaisons. Si vous l'associez à un profilé métallique en option pour le côté, l'esthétique et la préciosité seront celles d'une porte avec cadre.











11 / **Filo+ Plain**

Tortora Opaco / Top Campus Tortora

Tortora matt / Vanity top Campus - Tortora

Tortora matt / Waschtisch Campus - Tortora

Tortora mat / Plan vasque Campus - Tortora

Comp. FP 11 L.145,4 X P.45,9 cm













12 / **Filo+ Plain**

Piombo Opaco / Top Ecomalta Piombo

Piombo matt / Top Ecomalta with integrated basin - Piombo

Piombo matt / Abdeckplatte Ecomalta mit integriertem Becken - Piombo

Piombo mat / Plan Ecomalta avec vasque intégrée - Piombo

Comp. FP 12 L.205,4 X P.45,9 cm











Nuove specchiere componibili Tangram

Tangram non è un semplice specchio ma un vero sistema componibile. Tre forme geometriche, tre colori, specchi o elementi con contenimento. Accostare, distanziare, traslare sono le parole chiave per progettare la specchiera su misura in grado di adattarsi ad ogni ambiente e ad ogni richiesta.

Tangram: modular mirrors. Tangram is not a simple mirror but a real modular system. 3 geometric shapes, 3 colours, simple mirrors or mirror cabinets. You can put one near the other, distance them or even translate them: these are the keywords to design a customisable mirror capable of adapting to any environment and request.

Tangram: modulare Spiegel. Tangram ist nicht nur einfach ein Spiegel, sondern ein echtes modulares System. 3 geometrische Formen, 3 Farben, einfach der Spiegel oder ein Spiegelschrank. Verbinden, Distanzieren, Umstellen sind die Schlüsselwörter, um einen personalisierten Spiegel zu entwerfen, der sich an jede Umgebung und jede Anforderung anpassen kann.

Tangram: Miroirs modulaires. Tangram n'est pas un simple miroir mais un véritable système modulaire. 3 formes géométriques, 3 couleurs, simple miroirs ou miroirs armoires. Joindre, éloigner, déplacer sont les mots clés pour concevoir le miroir sur mesure capable de s'adapter à n'importe quelle salle de bain ou demande.







13 / **Filo+ Plain**

Rosa Cipria Opaco / Top Tender Bianco Opaco
Rosa Cipria matt / Vanity top Tender - White matt
Rosa Cipria matt / Waschtisch Tender - Weiß matt
Rosa Cipria mat / Plan vasque Tender - Blanc matt

Comp. FP 13 L.120,4 X P.45,9 cm



14 / **Filo+ Plain** ---

Bianco Opaco / Top Cover Bianco Opaco
White matt / Vanity top Cover - White matt
Weiß matt / Waschtisch Cover - Weiß matt
Blanc matt / Plan vasque Cover - Blanc matt

Comp. FP 14 L.95,4 X P.45,9 cm



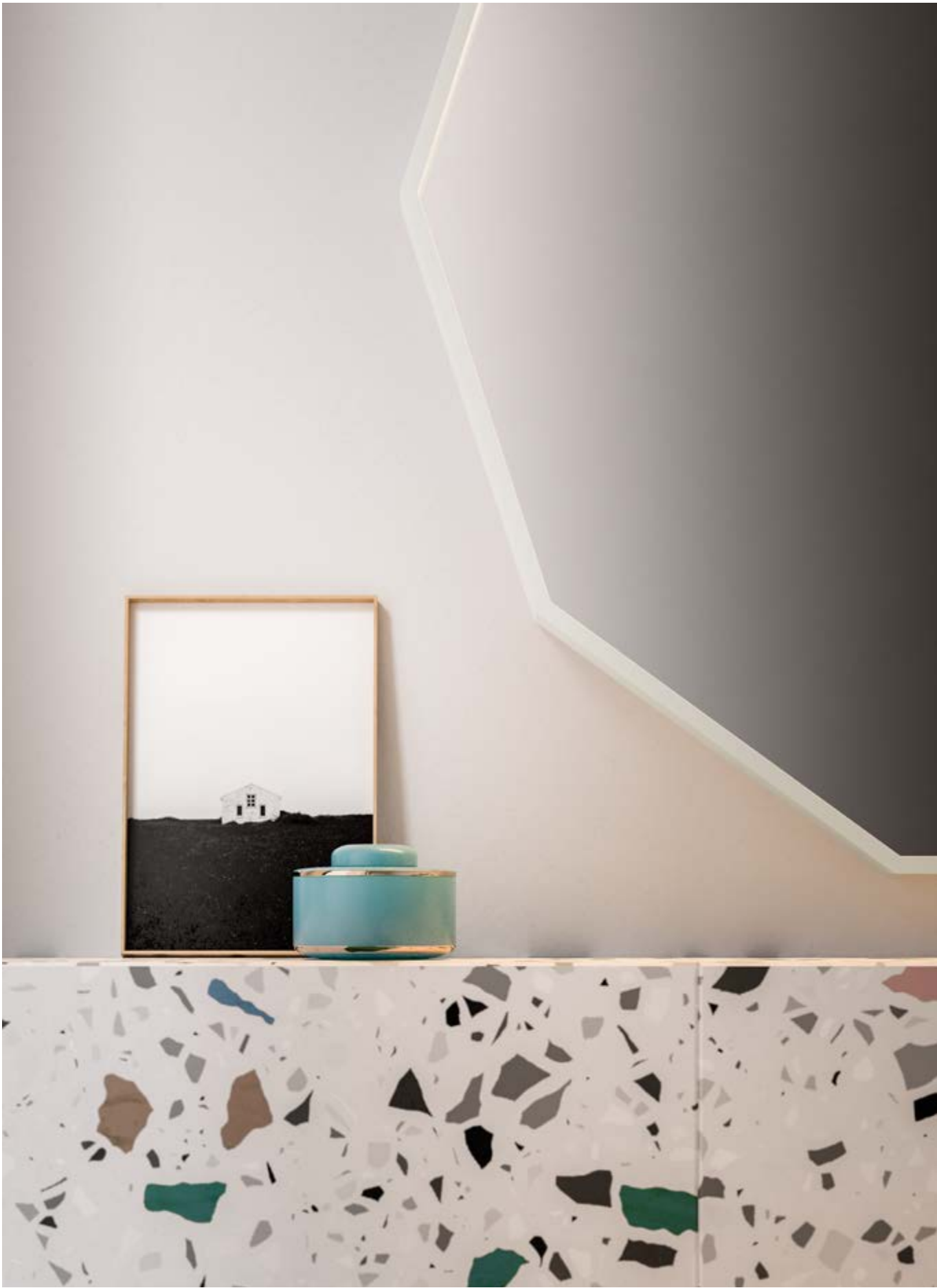



15 / **Filo+ Plain**

Pietra Grigia / Top Smart Bianco Opaco

Pietra Grigia / Vanity top Smart - White matt

Pietra Grigia / Waschtisch Smart - Weiß matt

Pietra Grigia / Plan vasque Smart - Blanc matt

Comp. FP 15 L.210,4 X P.50,4 cm









Filo+

———— Push & Handles

Semplice nella sua eleganza ed essenzialità, esclusiva e personalizzabile grazie alle molteplici possibilità di abbinamento. L'intramontabile pulizia estetica dell'anta push o il segno grafico e funzionale di una maniglia, esprimono la capacità di rendere sartoriale ogni progetto, di realizzare ogni composizione come un abito "su misura".

Simple in its elegance and essentialism, exclusive and customizable thanks to the many matching possibilities. Both the timeless aesthetic simplicity of a door with the push-to-open system and the graphic and functional form of the handle express the ability to make every project sartorial, to give to each composition a "tailored" suit look.

Einfach in seiner Eleganz und Einfachheit, exklusiv und anpassbar dank der vielen Kombinationsmöglichkeiten. Sowohl die zeitlose ästhetische Eingängigkeit einer Tür mit dem Push-to-Open-System als auch die grafische und funktionale Form des Griffs drücken die Fähigkeit aus, jedes Projekt als ein Schneiderhandwerk durchzuführen und jeder Komposition einen "maßgeschneiderten" Anzug-Look zu verleihen.

Simple par son élégance et son caractère essentiel, exclusif et personnalisable grâce aux nombreuses possibilités de combinaison. Tant la simplicité esthétique intemporelle d'une porte avec le système push-to-open (mouvement par pression pour ouvrir) que la forme graphique et fonctionnelle de la poignée expriment la capacité de créer des projets de couture, pour donner à chaque composition un look de costume "sur mesure".









16 / **Filo+ Push**

Blu Cobalto Opaco / Top Rail Bianco / Blu Cobalto Opaco

Blu Cobalto matt / Vanity top Rail - Blu Cobalto

Blu Cobalto matt / Waschtisch Rail - Blu Cobalto

Blu Cobalto mat / Plan vasque Rail - Blu Cobalto

Comp. FP 16 L.70,4 + 70,4 X P.45,9 cm















17 / **Filo+ Push**

Creta Opaco / Top Ecomalta Creta

Creta matt / Top Ecomalta with integrated basin - Creta

Creta matt / Abdeckplatte Ecomalta mit integriertem Becken - Creta

Cretamat / Plan Ecomalta avec vasque intégrée - Creta

Comp. FP 17 L.230,4 X P.50,4 cm





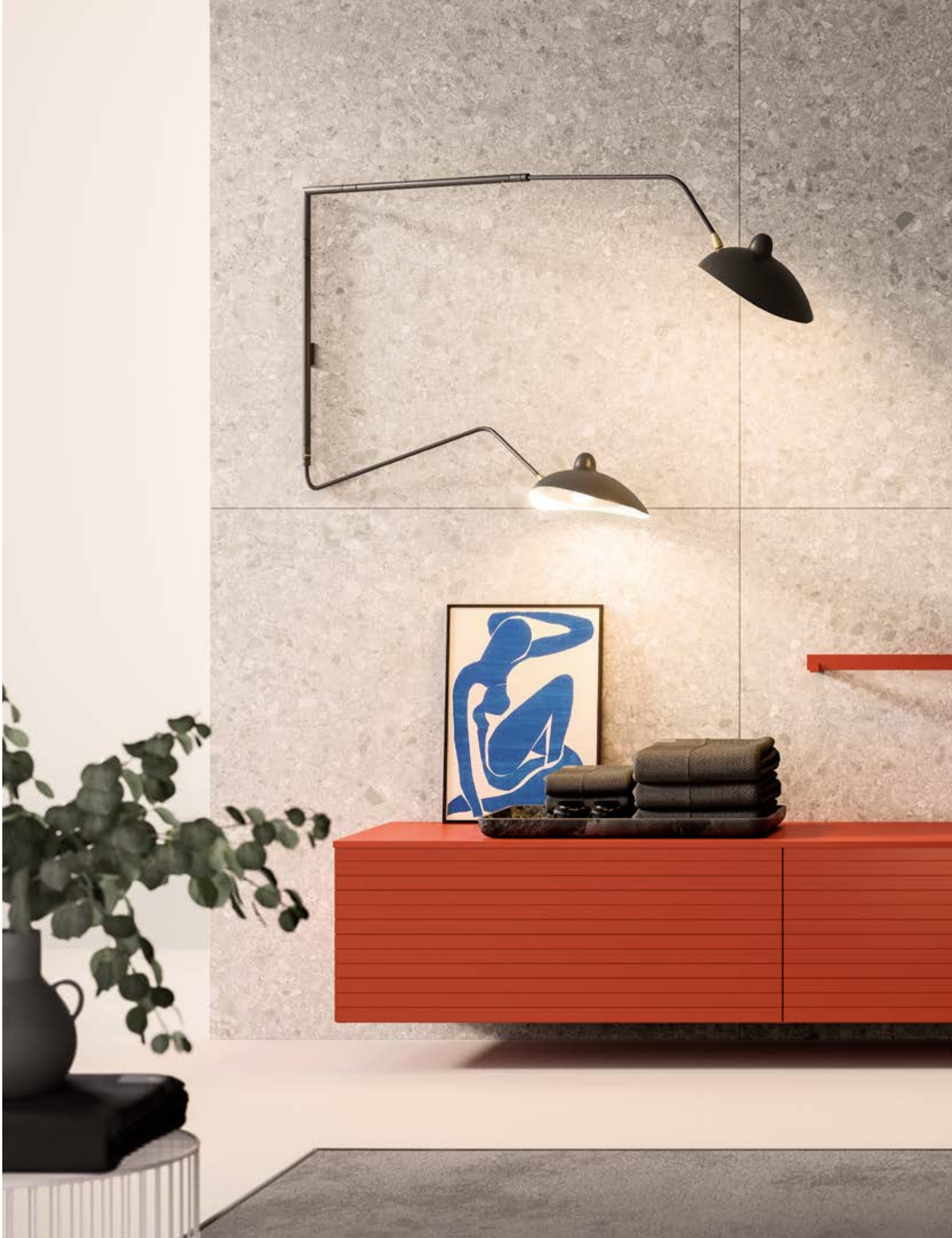





18 / **Filo+ Push**

Mattone Opaco / Totem Sirio Bianco Opaco
Mattone matt / Free standing basin Sirio - White matt
Mattone matt / Säulen-becken Sirio - Weiß matt
Mattone mat / Lavabo à colonne Sirio- Blanc matt

Comp. FP 18 L.190,4 + 75 X P.45,9 cm

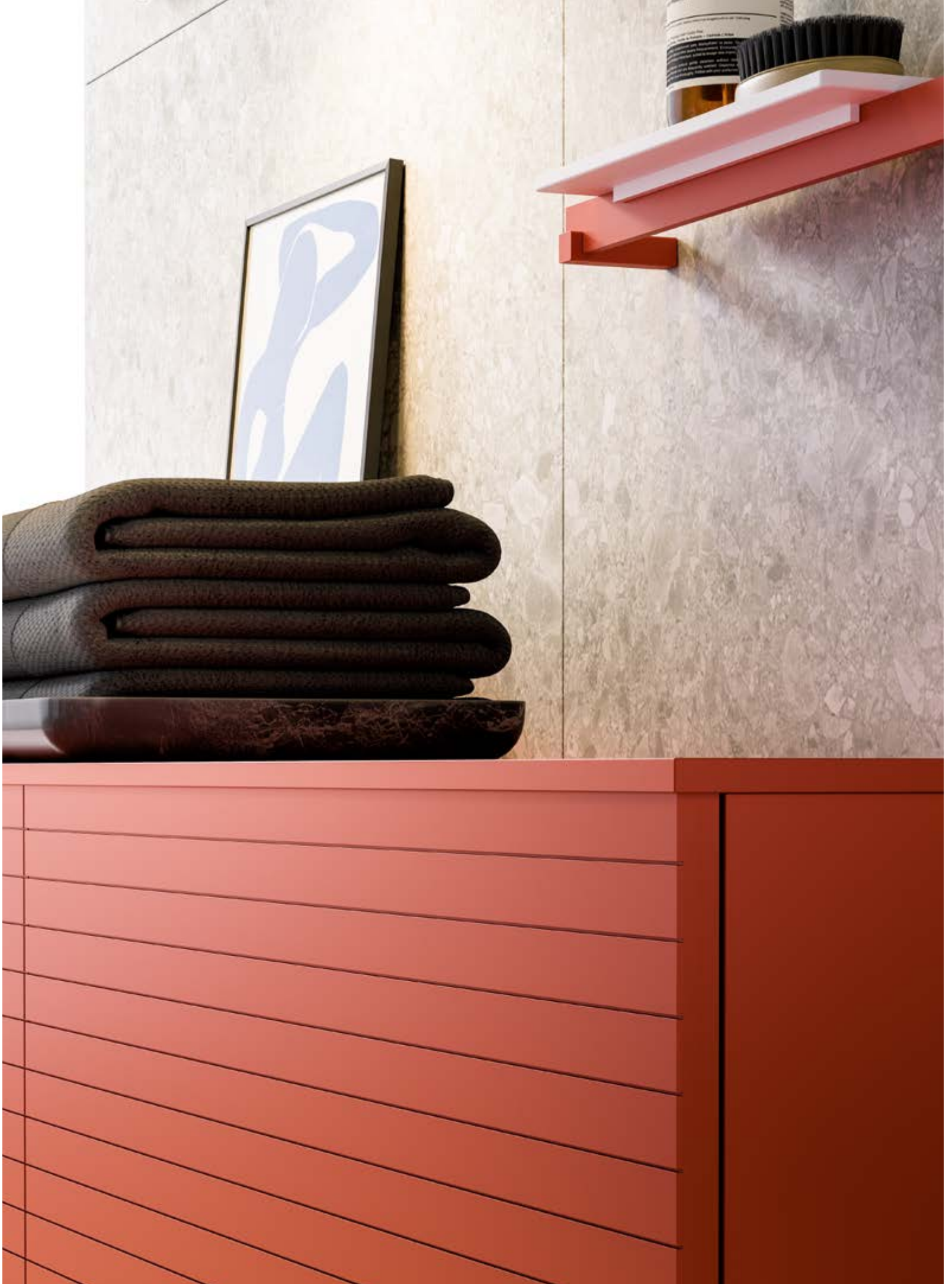



19/

Filo+ Push —————

Creta Opaco / Top Street Bianco Opaco
Creta matt / Vanity top Street - White matt
Creta matt / Waschtisch Street - Weiß matt
Creta mat / Plan vasque Street - Blanc matt

Comp. FP 19 L.120,4 X P.45,9 cm













20 / **Filo+ Push**

Bordeaux Opaco / Top Folding Pietra Rosa / Lavabo Elite Bianco Opaco

Bordeaux matt / Melamine Folding top Pietra Rosa / Basin Elite - White matt

Bordeaux matt / Folding Abdeckplatte aus Melamin Pietra Rosa / Becken Elite - Weiß matt

Bordeaux mat / Plan Folding en mélamine Pietra Rosa / Lavabo Elite - Blanc mat

Comp. FP 20 L.230 X P.50,4 cm





21 / **Filo+ Push & Handles**

Piombo Opaco / Top Campus Piombo
Piombo matt / Vanity top Campus Piombo
Piombo matt / Waschtisch Campus Piombo
Piombo mat / Plan vasque Campus Piombo

Comp. FP 21 L.280,4 X P.45,9 cm















22 / **Filo+ Handles**

Fango Opaco / Top Fango Opaco / Lavabi Hole Bianco Opaco
Fango matt / Lacquered top Fango matt / Basins Hole -White matt
Fango matt / Lackierte Abdeckplatte Fango matt / Becken Hole -Weiß matt
Fango mat / Plan laqué en Fango mat / Lavabos Hole - Blanc mat

Comp. FP 22 L.170,4 X P.50,4 cm







23/

———— Filo+ Handles

Nebbia Opaco / Top Tender Bianco Opaco
Nebbia matt / Vanity top Tender - White matt
Nebbia matt / Waschtisch Tender - Weiß matt
Nebbia mat / Plan vasque Tender - Blanc matt

Comp. FP 23 L.165,4 X P.45,9 cm





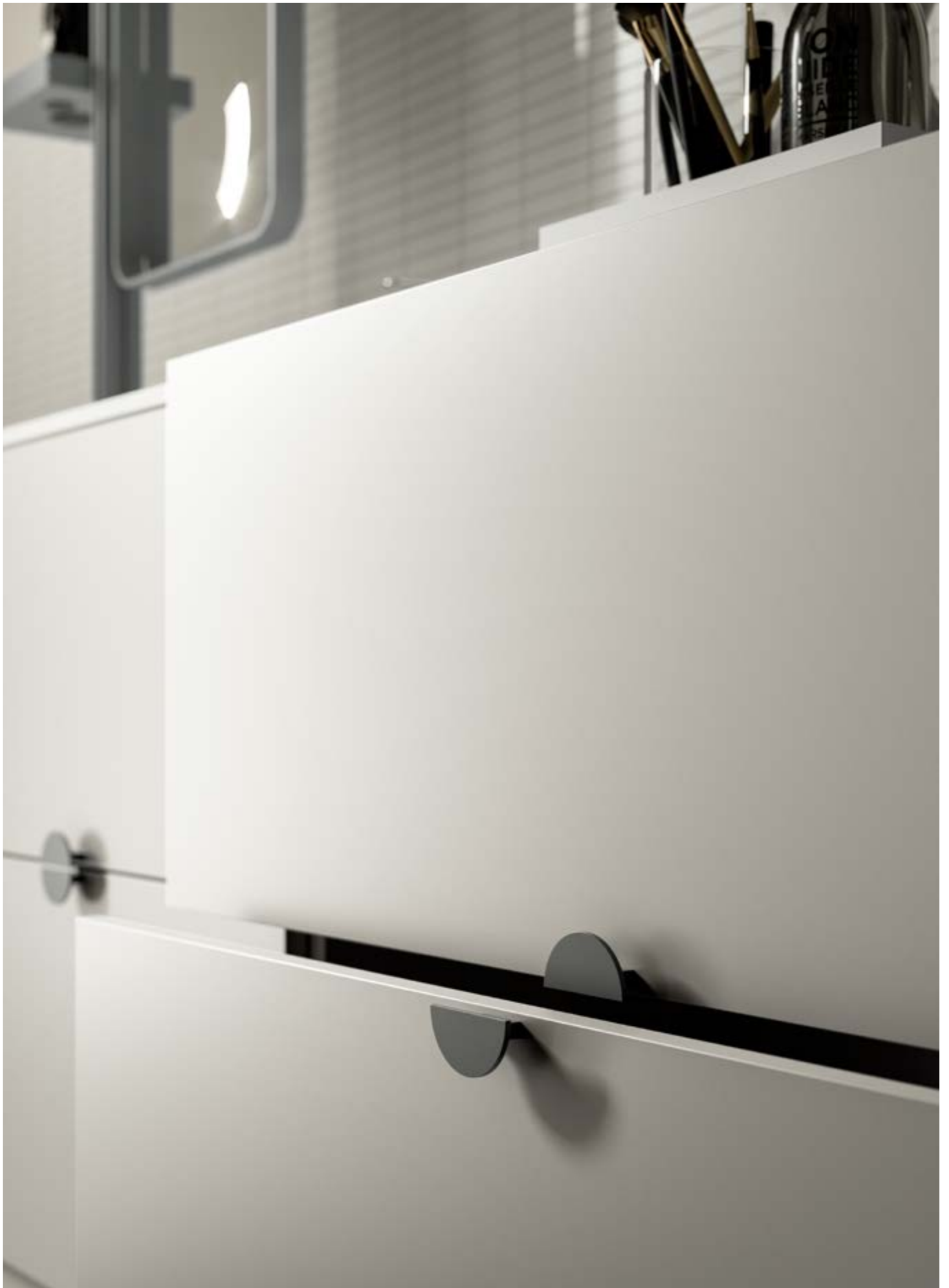

24/

Filo+ Handles

Verde Palude Opaco / Top Gres Azalai Nero

Verde Palude matt / Top in porcelain stone Gres Azalai Nero with integrated basin

Verde Palude matt / Abdeckplatte aus Feinsteinzeug Gres Azalai Nero mit integriertem Becken

Verde Palude mat / Plan en grés cérame Gres Azalai Nero avec vasque intégrée

Comp. FP 24 L.170,4 X P.45,9 cm







Filo+

—— Spazio
e ordine al
tuo servizio.

Un sistema che può rispondere anche alle esigenze funzionali della lavanderia. Nella sua funzione di servizio, mantiene tutta la sua bellezza creando uno spazio ordinato e versatile. Libertà compositiva per garantire un giusto compromesso tra estetica e funzionalità.

Space and order at your service.

A system that can also meet the practical needs of the laundry room. While corresponding to the concept of being a room with practical functionality, the laundry maintains in the meantime all its beauty, thanks to this collection that creates an orderly and versatile space. Freedom of planning a furniture composition that guarantees a fair compromise between aesthetics and practicality.

Platz und Ordnung zu Ihren Diensten.

Eine Kollektion, die auch die praktischen Anforderungen der Waschküche erfüllt. Diese entspricht zwar dem Konzept, ein Raum mit praktischer Funktionalität zu sein, behält aber gleichzeitig dank dieser Kollektion, die einen geordneten und vielseitigen Raum anbietet, ihre ganze Schönheit.

Die Freiheit um eine Möbelzusammenstellung zu planen, die einen fairen Kompromiss zwischen Ästhetik und Zweckmässigkeit garantiert.

Espace et ordre à votre service.

Un système qui peut également répondre aux besoins fonctionnels de la buanderie. Tout en correspondant au concept d'être une pièce aux fonctionnalités pratiques, la buanderie conserve quand même toute sa beauté, grâce à cette collection qui crée un espace ordonné et polyvalent. Liberté de composition pour garantir un juste compromis entre esthétique et fonctionnalité.







25 / **Filo+ Handles**

Bianco Opaco / Top Lavatù Bianco Lucido

White matt / Vanity top Lavatù with washtub- White glossy

Weiß matt / Waschtisch Lavatù mit Washtrog- Weiß Hochglanz

Blanc mat / Plan vasque Lavatù avec bac à laver - Blanc brillant

Comp. FP 25 L.140,4 X P.65,4 cm





26 / **Filo+ Handles**

Ghiaccio Opaco / Consolle Plano Bianco Lucido
Ghiaccio matt / Vanity top Plano - White glossy
Ghiaccio matt / Waschtisch Plano - Weiß Hochglanz
Ghiaccio mat / Plan vasque Plano - Blanc brillant

Comp. FP 26 L.190,4 X P.50,5/65 cm





Componi il tuo Filo+

Plan your composition with Filo + / Planen Sie Ihre Komposition mit Filo +
/ Projetez votre composition avec Filo +

1 Scegli la **tipologia di anta**

Choose the door / Wählen Sie die Tür / Choisissez la façade

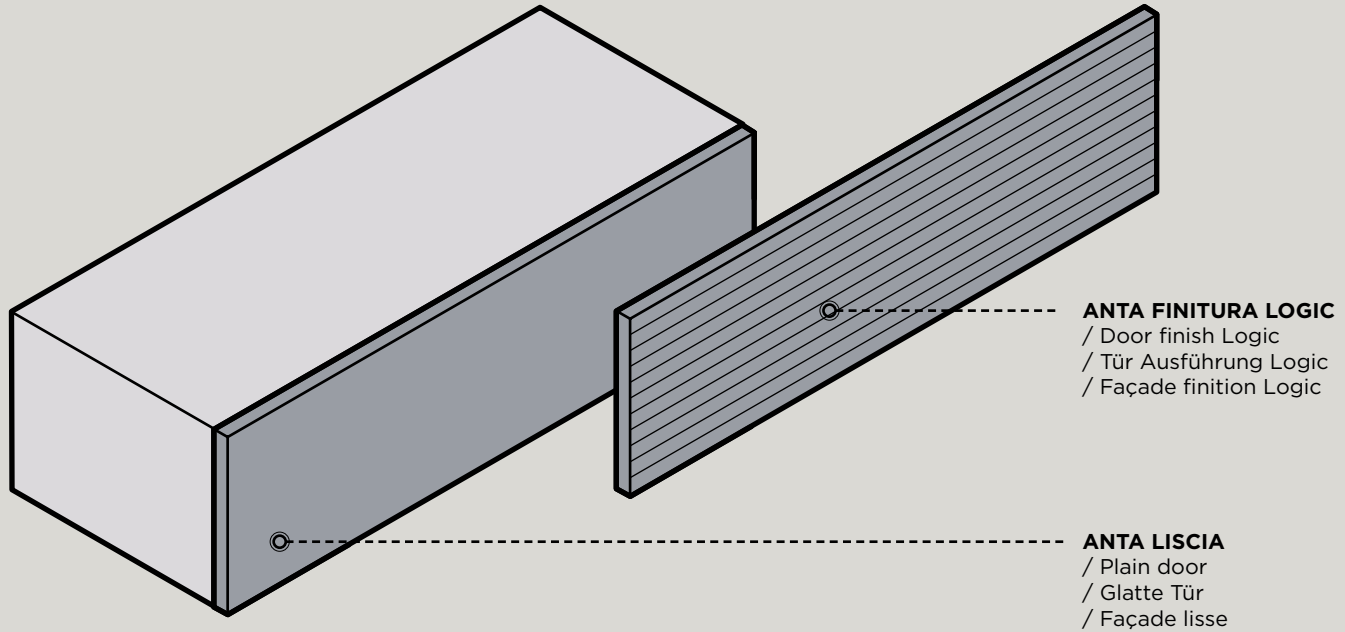

2 Scegli la **tipologia di apertura**

Choose the opening type / Wählen Sie den Öffnungstyp / Choisissez l'ouverture

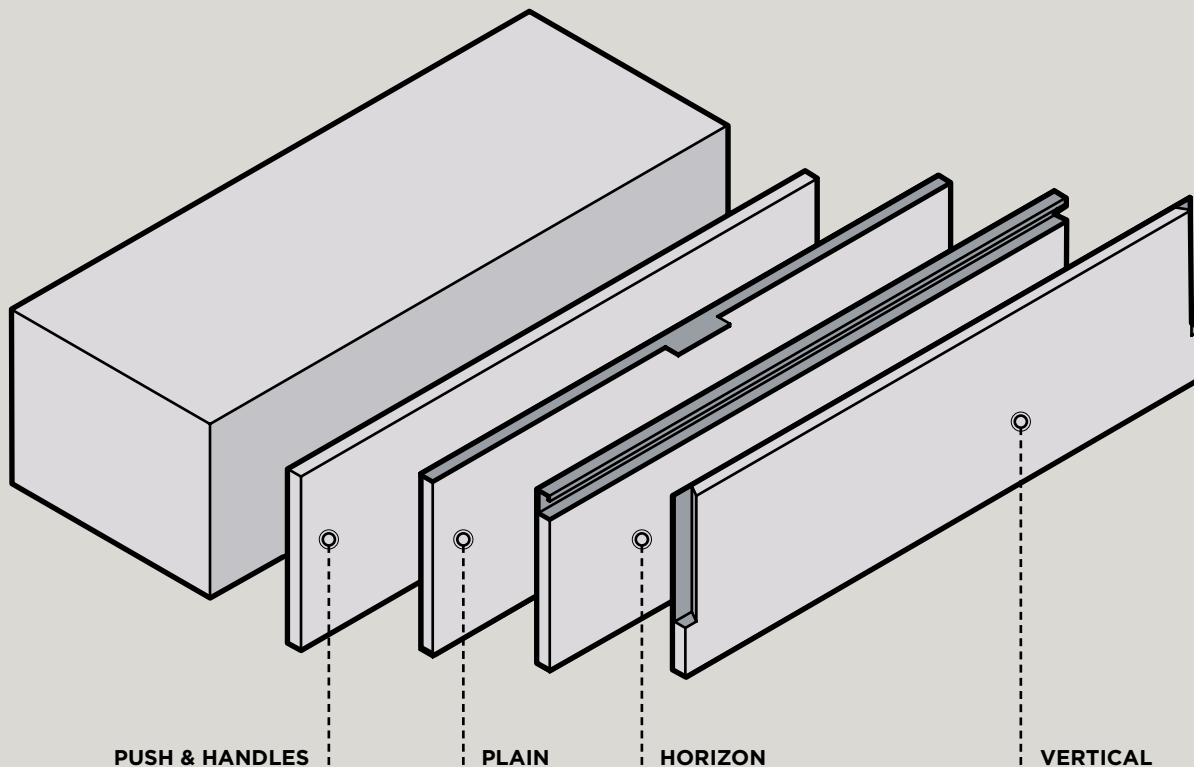

3 Scegli la tipologia di **spalle terminali**

Choose the side / Wählen Sie die Seiten / Choisissez le côté

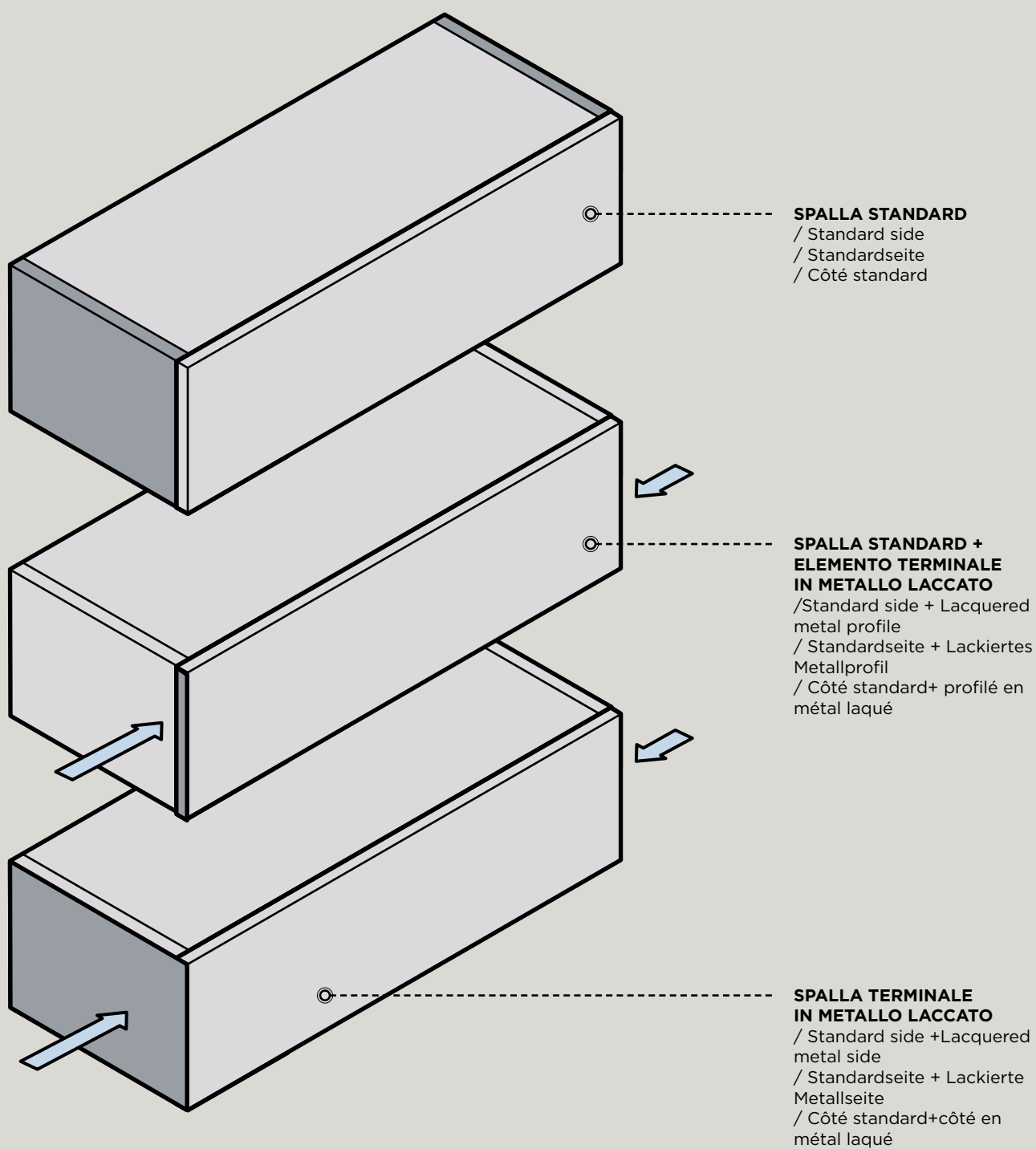

Filo+

Composizioni

- / Compositions
- / Zusammenstellungen
- / Compositions

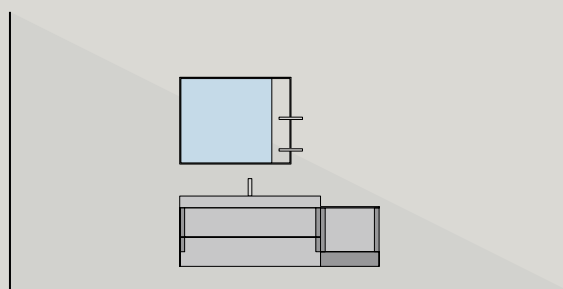

1 / Filo+ Vertical
Comp. FP 01 L.170,4 X P.45,9 cm

06

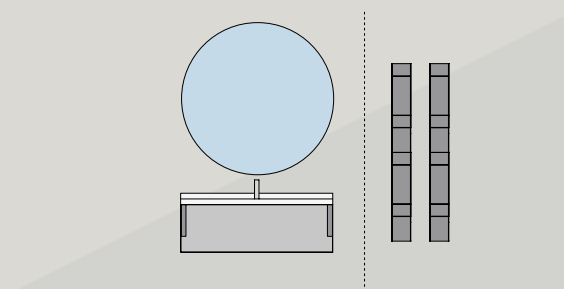

2 / Filo+ Vertical
Comp. FP 02 L.120,4 X P.50,4 cm

12

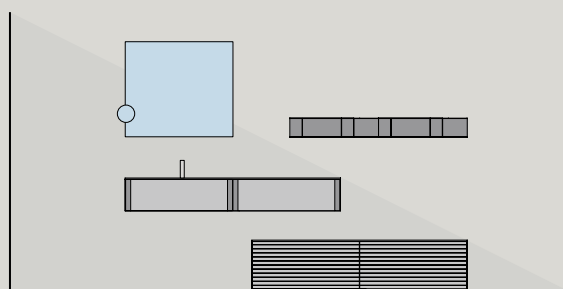

3 / Filo+ Vertical
Comp. FP 03 L.255,4 X P.45,9 cm

16

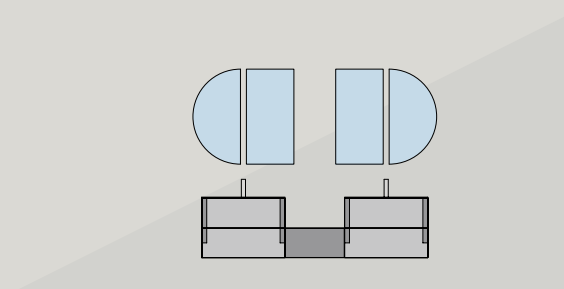

4 / Filo+ Vertical
Comp. FP 04 L.190,4 X P.51,5 cm

20

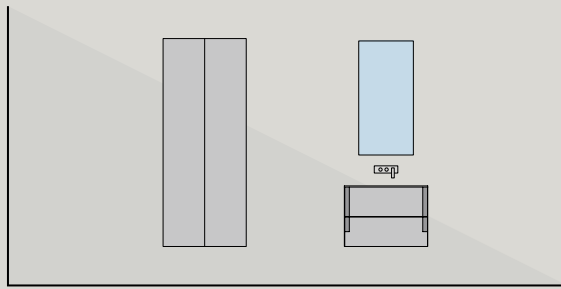

5 / **Filo+ Vertical**
Comp. FP 05 L.70,4 X P.50,4 cm

26 —

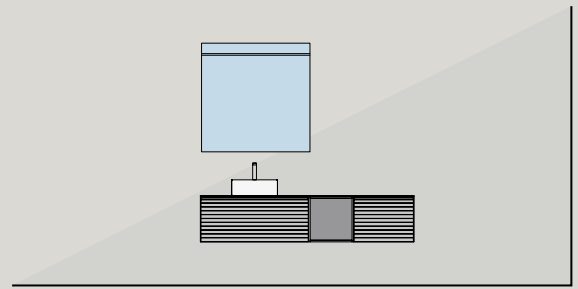

6 / **Filo+ Horizon**
Comp. FP 06 L.180,4 X P.45,9 cm

32 —

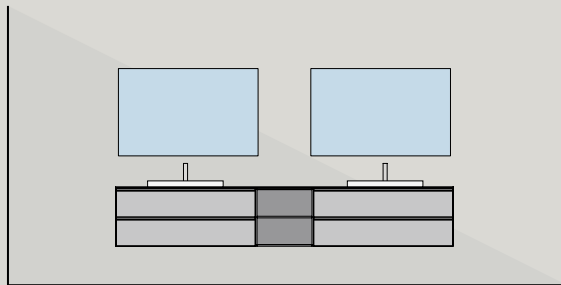

7 / **Filo+ Horizon**
Comp. FP 07 L.290,4 X P.50,4 cm

40 —

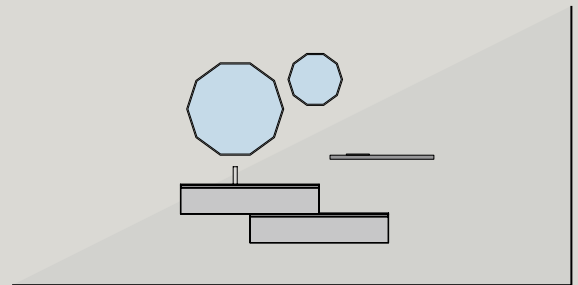

8 / **Filo+ Horizon**
Comp. FP 08 L.180,4 X P.45,9 cm

42 —

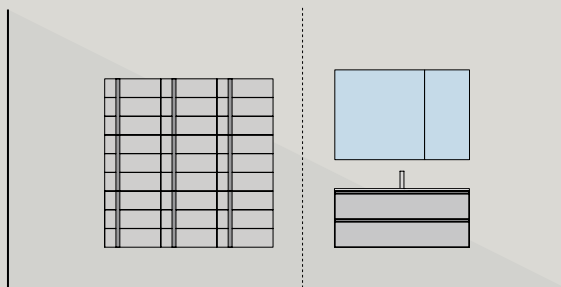

9 / **Filo+ Horizon**
Comp. FP 09 L.121 X P.51,5 cm

46 —

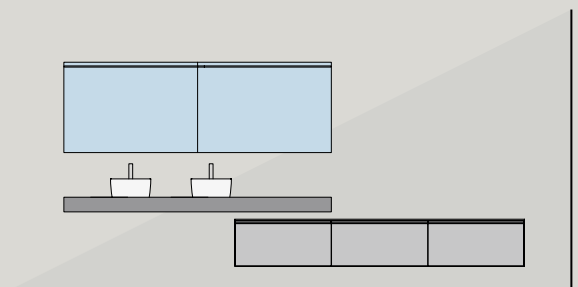

10 / **Filo+ Horizon**
Comp. FP 10 L.350 X P.45,9 cm

52 —

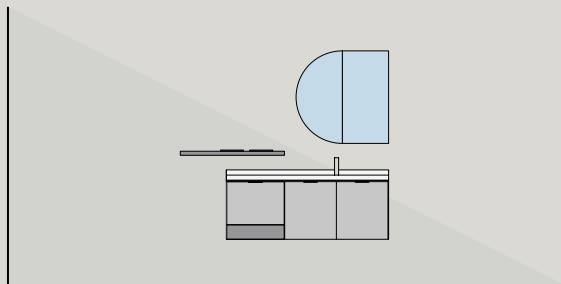

11 / **Filo+ Plain**
Comp. FP 11 L.145,4 X P.45,9 cm

58 —

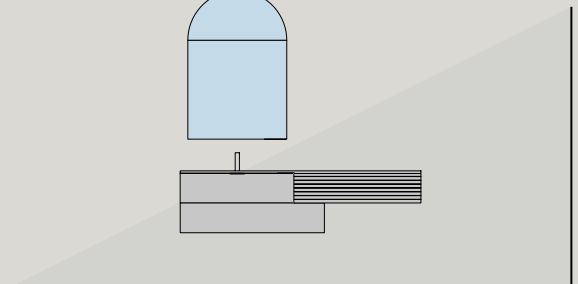

12 / **Filo+ Plain**
Comp. FP 12 L.205,4 X P.45,9 cm

64 —

define **your** space

Define your space / Wählen Sie Ihre Räume / Choisissez vos espaces

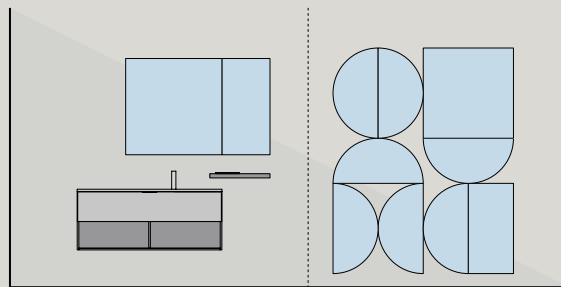

13 / **Filo+ Plain**
Comp. FP 13 L.120,4 X P.45,9 cm

70 —

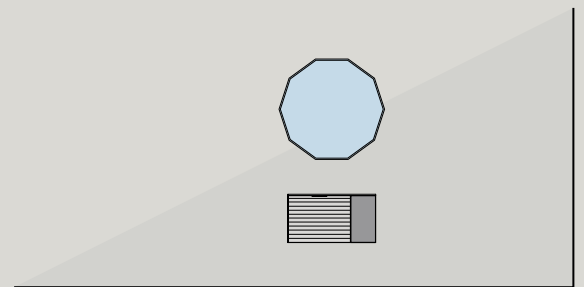

14 / **Filo+ Plain**
Comp. FP 14 L.95,4 X P.45,9 cm

76 —

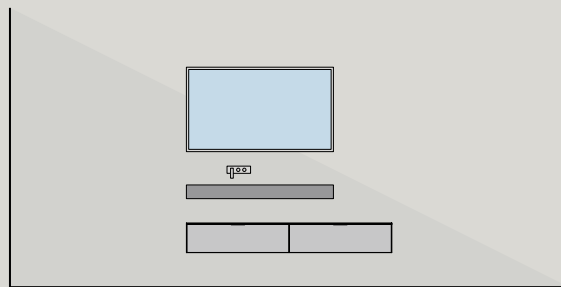

15 / **Filo+ Plain**
Comp. FP 15 L.210,4 X P.50,4 cm

80 —

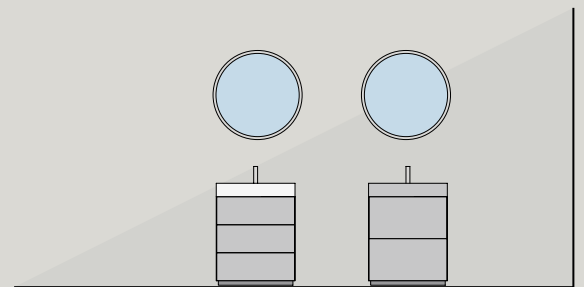

16 / **Filo+ Push**
Comp. FP 16 L.70,4 + 70,4 X P.45,9 cm

86 —

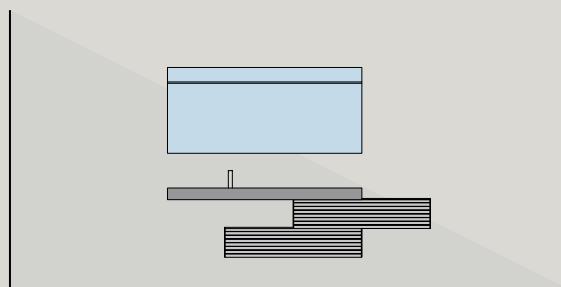

17 / **Filo+ Push**
Comp. FP 17 L.230,4 X P.50,4 cm

92 —

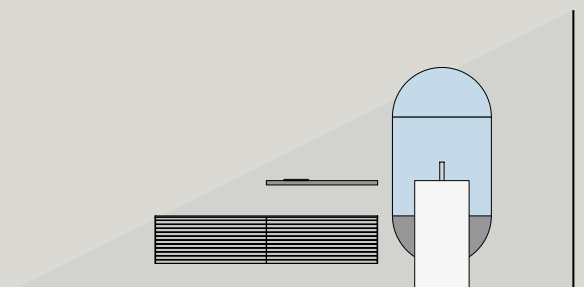

18 / **Filo+ Push**
Comp. FP 18 L.190,4 + 75 X P.45,9 cm

98 —

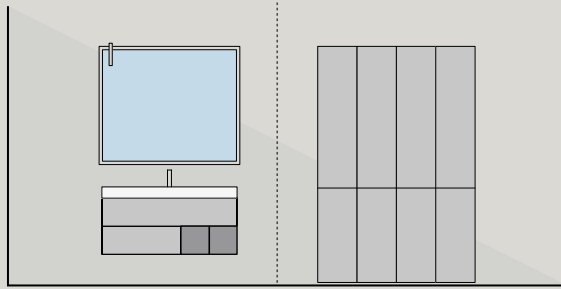

19 / **Filo+ Push**
Comp. FP 19 L.120,4 X P.45,9 cm

102 —

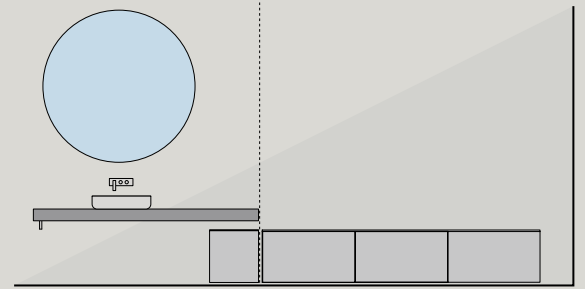

20 / **Filo+ Push**
Comp. FP 20 L.230 X P.50,4 cm

106 —

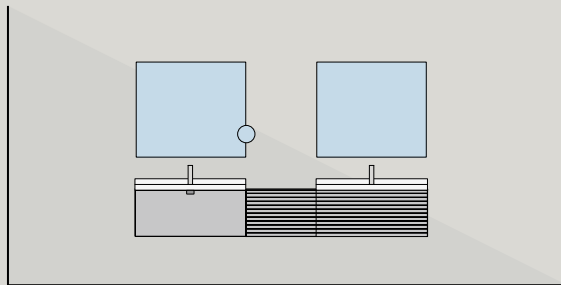

21 / **Filo+ Push & Handles**
Comp. FP 21 L.280,4 X P.45,9 cm

110 —

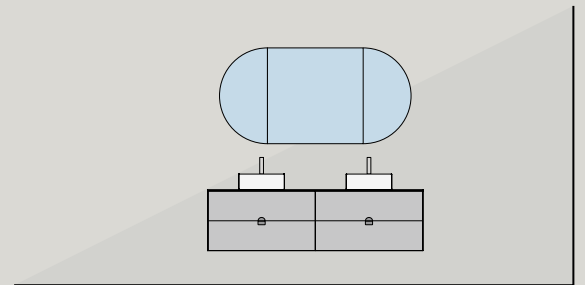

22 / **Filo+ Handles**
Comp. FP 22 L.170,4 X P.50,4 cm

116 —

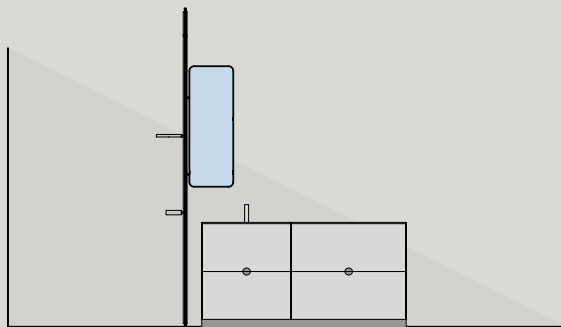

23 / **Filo+ Handles**
Comp. FP 23 L.165,4 X P.45,9 cm

122 —

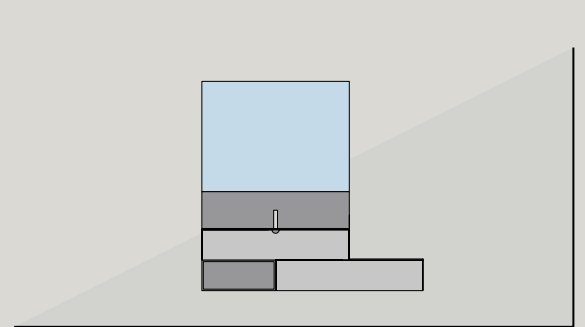

24 / **Filo+ Handles**
Comp. FP 24 L.170,4 X P.45,9 cm

126 —

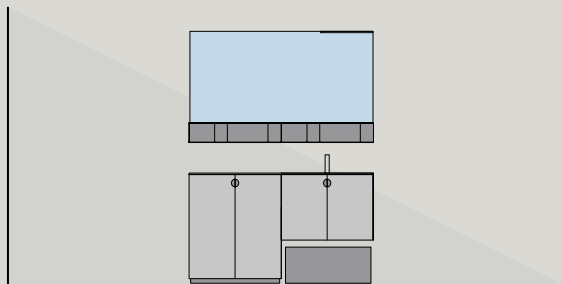

25 / **Filo+ Handles**
Comp. FP 25 L.140,4 X P.65,4 cm

132 —

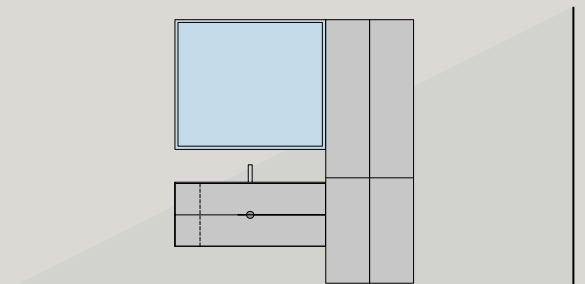

26 / **Filo+ Handles**
Comp. FP 26 L.190,4 X P.50,5/65 cm

134 —

Certificazioni

Certification / Beurkundungen/ Certification



MADE IN ITALY

Sicurezza e durata

Le scocche sono garantite dal marchio Idropan, uno speciale melaminico idrorepellente, resistente all'acqua e all'umidità, che contraddistingue l'anima nascosta dei mobili di qualità. L'azienda inoltre ha aderito al consorzio del pannello ecologico e utilizza cioè solamente pannelli realizzati con materiale riciclato al 100%. Tutti gli elementi sono studiati per vivere il bagno in tutta sicurezza ogni giorno: cerniere brevettate, agganci e finiture testate contro l'azione dell'umidità, ruote adatte per i contenitori, guide sotto-cassetto a scomparsa, accessori elettrici certificati.

Safety and lifespan

Our furniture structures are guaranteed by the Idropan brand, a special melamine-coated panel, which resists to water and dampness and characterizes furniture of quality. Moreover the company makes part of the consortium of the ecological panel, using only 100% recycled panels. All the elements are meant to facilitate the daily use of the bathroom in safety: patented hinges, hooks and finishes tested to resist to dampness, resistant wheels for cabinets, no visible slide runners under the drawers and certified electrical fittings.

Sicherheit und Dauer

Die Struktur wird von dem Markenzeichen Idropan garantiert, ein wasserabweisendes und Feuchtigkeit widerstehendes Spezialmelamin, das Qualitätsmöbel kennzeichnet. Das Unternehmen hat sich außerdem dem Konsortium des ökologischen Paneels angeschlossen und verwendet daher nur Paneele, die aus 100% aus Recyclingmaterial hergestellt wurden. Alle Elemente sind darauf ausgerichtet, das Bad in kompletter Sicherheit jeden Tag zu benutzen: patentierte Scharniere, Wandbefestigungen und Ausführungen, die auf die Einwirkung von Feuchtigkeit getestet sind, haltbare Räder für Rollwägen, versteckte Laufschienen unter den Schubladen, bescheinigte elektrische Zubehörteile.

Sécurité et durée

Les caissons sont garantis par la marque Idropan, un panneau mélaminé hydrofuge spécial, résistant à l'eau et à l'humidité, qui caractérise les meubles de qualité. La société a aussi adhéré au consortium du panneau écologique et utilise seulement des panneaux fabriqués avec du matériel recyclé au 100%. Tous les éléments sont étudiés pour vivre la salle de bain en toute sûreté tous les jours. Charnières brevetées, accroches et finitions testées contre l'humidité, roues pour chariots résistants, glissières pas visibles pour les tiroirs, accessoires électriques certifiées.

Seguridad y duración

Los costados son garantizados por medio de la marca Idropan, un especial melaminado idrorepelente resistente al agua y a la humedad que va a marcar la alma escondida de todos los muebles de calidad. La empresa además está asociada al consorcio tablero ecológico y utiliza solo tableros efectuados con materiales reciclados por el 100%. Artesi estudio todos los elementos para vivir el ambiente baño cada día con toda seguridad: bisagras patentadas, enganches y acabados frentes que contrastan la acción de la humedad, ruedas de los contenedores, guías bajos cajones ocultas, componentes eléctricos certificados.



Materiale idrofugo di qualità resistente all'acqua ed all'umidità.

Waterproof material resistant to water and dampness.

Wasserabweisendes hochwertiges Material, das Wasser und Feuchtigkeit widersteht.

Matériel hydrofuge de haute qualité, résistant à l'eau et à l'humidité.

Material hidrófugo de calidad resistente al agua y a la humedad.



Pannello ecologico garantito 100% Legno riciclato.

Ecological panel made of 100% Recycled wood.

Ökologisches paneel, 100% aus Recyclingmaterialhergestellt.

Panneau écologique fabriqué en bois recyclé au 100%.

Tablero ecológico garantizado por el 100% de Maderas recicladas.



Marchio europeo di qualità Per i componenti elettrici.

European quality label for electrical components.

Europäisches qualitätsmarkenzeichen für elektrische Komponenten.

Label de qualité européen pour les composants électriques.

Marca Europea de calidad por los componentes eléctricos.



Artesi ha un proprio Sistema di Gestione della Qualità, certificato dall'ente ICILA, secondo la norma UNI EN ISO 9001:2015. Tale certificazione ha lo scopo di gestire al meglio ogni processo aziendale. Il sistema qualità Artesi, attraverso un'accurata progettazione, selezione e controllo dei fornitori e dei processi produttivi, persegue il principale obiettivo della piena soddisfazione dei propri clienti.

Artesi has an own Quality Management System certificated by ICILA according to the UNI EN ISO 9001:2015 regulation. This certification aims at conducting every company process in the best way. The quality system of Artesi hits the main target of the customer's full satisfaction by a careful planning, selection and control of the suppliers and the production procedures.

Artesi verfügt über ein eigenes, seitens der ICILA bescheinigtes Qualitätssystem gemäß UNI EN ISO 9001:2015-Norm. Dieses Zertifikat ist darauf ausgerichtet, jeden Betriebsvorgang in der bestmöglichen Weise zu führen. Das Qualitätssystem der Firma Artesi verfolgt hauptsächlich das Ziel, die eigenen Kunden mittels einer sorgfältigen Planung, Auswahl und Kontrolle der Lieferanten und der Produktionsverfahren voll zufriedenzustellen.

Artesi dispose d'un propre système de gestion de la qualité certifié ICILA selon la norme UNI EN ISO 9001:2015. Cette certification a le but de gérer au mieux chaque procédé de l'entreprise. Le système de qualité Artesi poursuit l'objectif principal de la pleine satisfaction du client par un projet soigneux, la sélection et le contrôle des fournisseurs et des procédés de production.

Artesi posee un sistema de gestión calidad, certificado por el ente ICILA, según la norma UNI EN ISO 9001:2015. Esa certificación tiene el fin de administrar en el mejor modo posible cada proceso de la empresa. El sistema de calidad Artesi, por medio de un cuidadoso planeamiento, selección y control de los proveedores y de los procesos productivos, persegue como principal objetivo la plena satisfacción de sus clientes.

AD
Progetto grafico
Rendering
styling
Fotolito
Stampa

Enrico Cesana
CO3 Design Studio
Nudesignstudio
Massimiliano Di Domenico
Nudesignstudio
--
Maggio 2020